

CONTROLSTIK II RINSE TANK SYSTEM

Model 597

Operation Manual

INSTALLATION • OPERATION • MAINTENANCE

21 October 08

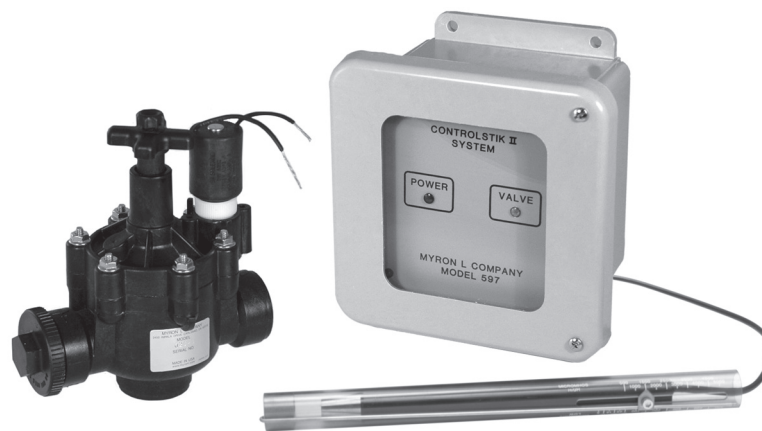

ACCURACY • RELIABILITY • SIMPLICITY

**MYRON L
COMPANY**
Water Quality Instrumentation
Accuracy • Reliability • Simplicity

PLEASE READ THIS THROUGH COMPLETELY BEFORE ATTEMPTING TO INSTALL OR OPERATE THIS SYSTEM.

DESCRIPTION

The Myron L Controlstik Rinse Tank System is a fully automatic control which will greatly reduce the amount of water used in continuous flow rinse tanks. At the same time, it automatically maintains water quality, insuring effective rinsing in water up to 82°C (180°F). It operates on the electrical conductivity principle and is fully stable and protected against all environmental conditions including temperature, line voltage, water contamination and corrosion.

Controlstik Rinse Tank System has three major parts:

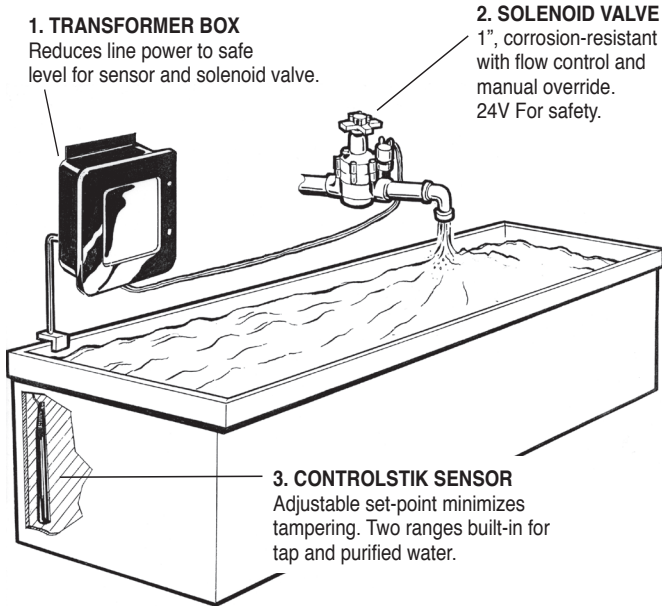

After installation, the Controlstik (sensor) is submerged in the rinse water. When contamination (drain) accumulates beyond the point "safe" for good rinsing, the sensor automatically opens the Solenoid Valve. Fresh water flows into the tank, and as excessive contamination is diluted back to the "safe" level, the sensor closes the valve, limiting water use.

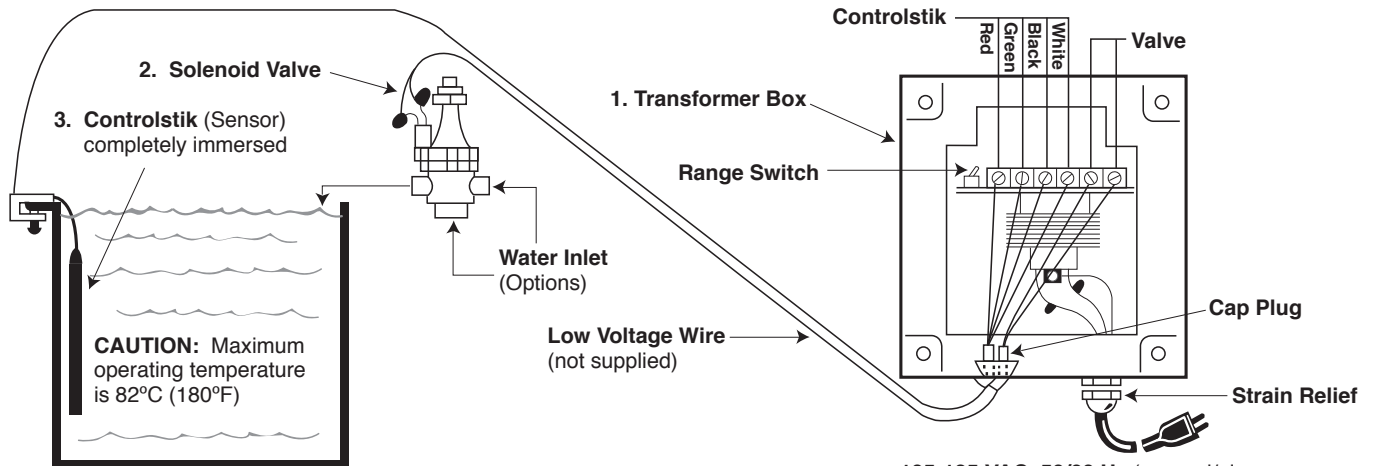

105-125 VAC, 50/60 Hz (no cord/plug supplied with 210-250 VAC 50/60 Hz model)

INSTALLATION AND OPERATION PROCEDURES

A. Mounting

Follow local electrical code

CAUTION: Do not apply power until all wiring has been completed and connections checked.

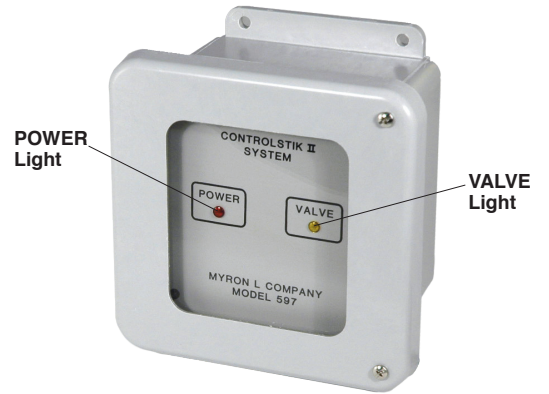

1. TRANSFORMER BOX

1. Mount the Transformer Box near the correct AC power as indicated on your unit. It may be hung on a wall, panel, or post.
2. Hang Controlstik (sensor) in the tank by the cord, using the securing clamp to hold the cord onto the edge of the tank. The sensor should hang vertically, fully submerged at least 10 cm (4 in.) off the tank bottom and not closer than 60 cm (2 ft.) to the inlet water line. If tank is small, locate sensor at end opposite from inlet.

NOTE: If water rate is slow or if drain rate and concentration prevent good diffusion of contamination ... the following should be considered to insure the Controlstik senses water that is "representative" of the entire tank:

1. Agitation - by air or other means
2. Installation of weir in tank perpendicular to water flow
3. Use of spider (sparge) on inlet

B. Piping

1. Install valve in inlet water line to rinse tank so that flow direction is as indicated by the arrows on the top of valve body.
2. Use Teflon tape on all connections and plug the unused inlet.
3. Insure flow control is at least partially open by turning counterclockwise.

NOTE: The 1-inch NPT valve supplied requires at least 10 psi (69 kPa) line pressure to operate. Increasing flow rate may allow valve to operate at lower pressure.

C. Wiring

1. Connect the four color coded wires from the Controlstik (sensor) to terminals in the Transformer Box marked Controlstik.
2. Obtain enough low voltage wire (at least 20 gauge) to connect solenoid valve to Transformer Box. Use pliers to attach spade lugs (provided) to wire. Connect wires to terminal strip in box as in diagram.
3. Recheck to be certain all connections are to correct terminals.

CAUTION: DO NOT short or connect the Controlstik (sensor) to the terminals marked **VALVE**; damage may result.

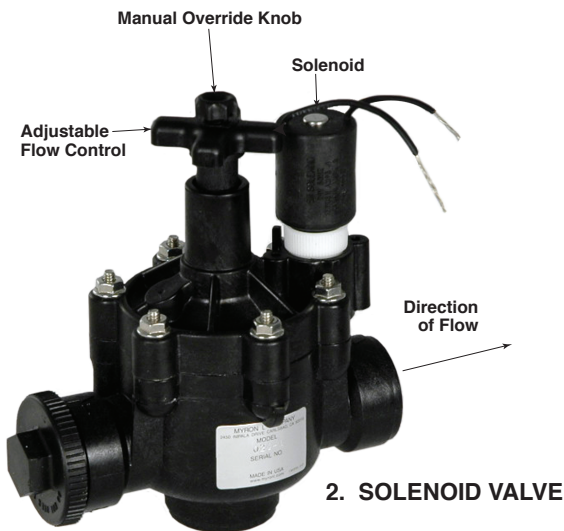

D. Testing

1. If controlling ordinary tap water, make sure Transformer Box range toggle switch is set on "HI" (toward back of box). If controlling purified (such as deionized) water, switch should be forward in "LO" position. Also, Controlstik sensor pointer should face in direction of High (500-5000 micromhos) or Low (5-500) scale to agree with Box range switch setting. To change pointer loosen set screw with 9/64 inch Allen wrench. Turn pointer to opposite scale. Lift the rod to the other side of the set screw and place back under the wide part of the pointer plate. Retighten set screw with fingers, allowing inside probe to move within sheath.

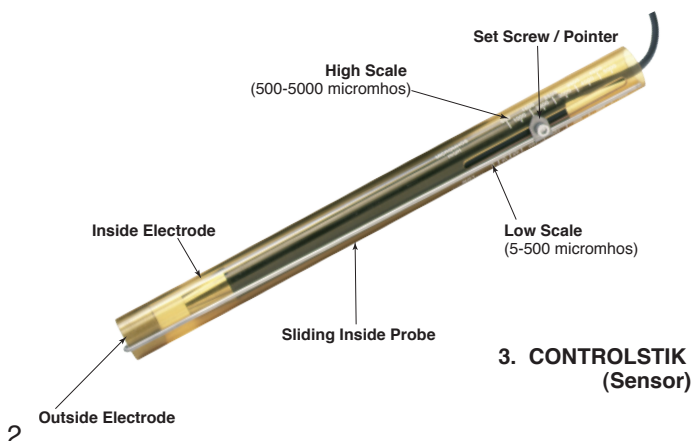

2. Turn on the power by connecting the transformer box to 120 Volt AC (or correct voltage for model being installed). POWER light on Transformer Box will glow.
3. Bring Controlstik (sensor) electrodes together by sliding the inside probe completely forward. Use a screwdriver to "short" the inside cone electrode to the outside band electrode. This "short" will turn on valve; VALVE light on Transformer Box will glow and valve will open.
4. Remove "short" between electrodes. VALVE light will go out and valve will shut off.

E. Initial Setting and Operation

1. Fill pail with water from rinse tank inlet water line.
2. Move inside probe of the Controlstik (sensor) back to highest scale reading and submerge into pail of water.
3. Slowly push inside probe toward opposite end, stopping when Solenoid Valve triggers and VALVE light goes on. Water will begin to flow into the tank. Read scale.
4. For the initial setting, move the inside probe back to read at least 25% higher than the scale reading in step 3. Tighten set screw with 9/64" Allen wrench (finger tight is not sufficient).
5. Place the Controlstik (sensor) back into the rinse tank as described under Section A. Mounting, number 2. Fasten the cord with the securing clamp provided.
6. Check setting and overall operation by rinsing parts or by pouring a small amount of acid or alkaline solution into the rinse tank to trigger the Solenoid Valve and start water flow.
7. Adjust valve flow control handle to obtain desired flow rate. Check through at least one complete on/off cycle. This valve can also be operated manually. To disengage the solenoid (convert valve to manual operation) hold the cross handle firmly and loosen (counterclockwise) the bolt in the center of the stem. Some water will spurt out at the stem while it is under manual control.

NOTE: The best Controlstik (sensor) setting can be determined with experience. Since the main objective of the system is to conserve water use, a high conductivity setting on the sensor is desirable . . . as long as the water does not become too dirty, preventing effective rinsing. However, if the sensor is set too low, the water will flow continuously due to the normal conductivity (total dissolved solids) in source water - defeating the purpose of the system.

MAINTENANCE

A. Controlstik (sensor)

Although this system is very stable, **the sensor should be regularly checked** for hard water scale, which will lower its sensitivity. Scale can be easily removed by agitating sensor in a 2-10% hydrochloric acid solution. If scale has been allowed to build up for a long period, a bristle brush may also be used. The Controlstik (sensor) may be disassembled by removing the set screw and thoroughly cleaned if it should accidentally become completely fouled.

B. Valve

Should the Controlstik Rinse Tank System no longer activate the Solenoid Valve when the inside probe is intentionally "shorted," unscrew the solenoid from the side of the valve and check the chamber for any solid matter which may prevent easy solenoid movement.

WARRANTY

This Myron L CONTROLSTIK System has a Two-Year Warranty. If this system fails to function normally, return the faulty unit of the system to the factory prepaid. If in the opinion of the factory, failure was due to materials or workmanship, repair or replacement will be made without charge. A reasonable service charge will be made for diagnosis or repairs due to normal wear, abuse or tampering. Warranty is limited to the repair or replacement of the units of the CONTROLSTIK System only. The Myron L Company assumes no other responsibility or liability.

OTHER MYRON L INSTRUMENTS USEFUL FOR FINISHING APPLICATIONS



The waterproof and microprocessor-based Ultrameter II Model 4P is a fast “on-the-spot” water quality tester. It offers highly accurate readings of 4 parameters: Conductivity, Total Dissolved Solids, Resistivity, and Temperature. The new Ultrameter II also offers download capabilities with the optional uDock™, is waterproof and bouyant, features a real time clock, and much more.



Model 6P has all the features of Ultrameter II 4P, but can also test for pH and ORP (redox). All electrodes are built into the cell cup for maximum protection. The extended-life pH/ORP sensor is user replaceable. This instrument is ideal for testing rinse water and RO/DI systems. This meter makes setting your Controlstik sensor even easier and allows you to test high quality deionized water.

Please visit www.myronl.com for more information on all Myron L products.

MYRON L COMPANY
2450 Impala Drive
Carlsbad, CA 92010-7226
USA
Tel: +1-760-438-2021
Fax: +1-760-931-9189

E-Mail: info@myronl.com
techquestions@myronl.com

www.myronl.com

Made in USA

ACCURACY • RELIABILITY • SIMPLICITY

MYRON L
COMPANY
Water Quality Instrumentation
Accuracy • Reliability • Simplicity
© Myron L Company 2008 597OM 10-08